



Unit 5L, Delta Drive, Tewkesbury, Glos. GL20 8HB. United Kingdom.

Ceramic Roller Guides



Part No.	Dimensions in mm			
	A	B	C	H
IWM1001	20	15	3.0	5
IWM1002	29	20	4.0	6.5
IWM1003	30	15	3.0	10
IWM1004	40	20	4.0	15
IWM1005	45	30	5.0	10
IWM1006	60	38	8.0	13
IWM1008	79.2	50	10.0	15

Our ceramic roller guides are made from fine Alumina (Al_2O_3), which provides excellent resistance to wear and reduces heat and friction.

The ceramic surfaces are polished to a mirror finish in order to reduce friction to a minimum.

The ceramic ring is enclosed in plastic flanges to reduce weight and inertia; the core of the ceramic part is mounted onto a precision bearing to optimise performance.

These rollers are normally used for guiding the wire during coil winding operations, but also have many applications in the wire manufacturing and textile industries.

Standard stock sizes are highlighted in green; all other sizes are available subject to minimum order quantities.

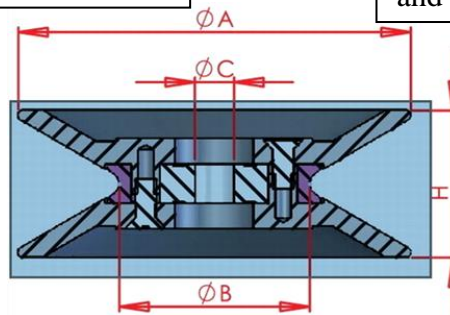

We aim to be much more than a machinery supplier. Our team has a vast range of winding experience and is able to offer help and advice on all aspects of coil winding, from tooling design to machine choice and set-up.

~ Coil winding solutions you can rely on ~



Working with local partners in the following countries;

Austria, Czech Republic, Germany, Hungary, Poland, Portugal, Romania, Slovakia, Slovenia, Spain, Sweden.



Unit 5L, Delta Drive, Tewkesbury, Glos. GL20 8HB. United Kingdom.

Ceramic Captive Rollers

Our ceramic captive rollers are made from fine Alumina (Al_2O_3), which provides excellent resistance to wear and reduces heat and friction.

The ceramic surfaces are polished to a mirror finish in order to reduce friction to a minimum.

The wire jump preventer is used in instances in which there are radical changes in direction and prevents wire jumping out of the pulley during winding processes.

There is a high speed bearing within the pulley's porcelain circle which keeps the sliding distance between the enamelled wire and the OD under 0.2mm.

Normally used for guiding the wire during coil winding operations, but also have many applications in the wire manufacturing and textile industries.

Standard stock sizes are highlighted in green; all other sizes are available subject to minimum order quantities.

Part No	Weight (g)
IWM-NT001	4
IWM-NT002	7.5
IWM-NT003	13.5
IWM-NT004	4
IWM-NT005	2
IWM-NT020	4.5
IWM-NT022	11.5

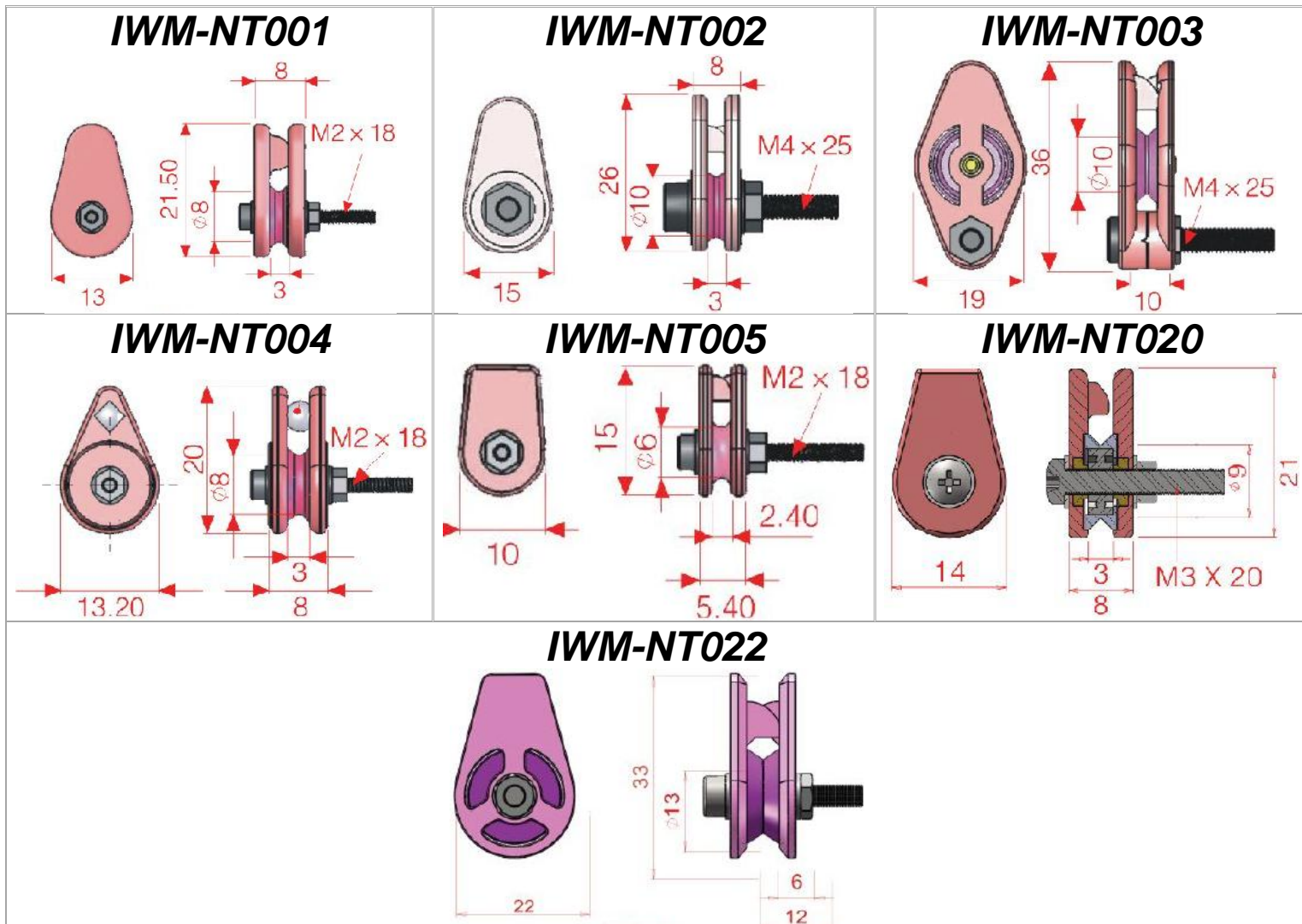

We aim to be much more than a machinery supplier. Our team has a vast range of winding experience and is able to offer help and advice on all aspects of coil winding, from tooling design to machine choice and set-up.

~ Coil winding solutions you can rely on ~



Working with local partners in the following countries;

Austria, Czech Republic, Germany, Hungary, Poland, Portugal, Romania, Slovakia, Slovenia, Spain, Sweden.



Unit 5L, Delta Drive, Tewkesbury, Glos. GL20 8HB. United Kingdom.

Ceramic Eyelet Guides and Grommets



Part No.	Dimensions in mm				
	A	B	C	D	E
IW-001	4.5	2.8	1.0	3.0	1.0
IW-002	5.0	3.5	2.4	3.6	1.0
IW-003	6.8	4.7	2.6	3.3	1.3
IW-004	10.0	7.2	4.8	8.8	1.7
IW-005	10.0	7.0	4.8	8.8	1.7
IW-006	11.0	8.0	3.7	9.2	3.0
IW-007	7.8	5.2	3.0	5.5	1.5
IW-008	9.2	7.0	4.5	8.0	2.0
IW-009	6.0	4.2	2.6	3.2	1.2
IW-010	10.2	6.2	4.2	10.0	2.0
IW-011	9.7	7.0	4.0	9.0	2.0
IW-012	6.0	3.8	2.0	3.6	1.0
IW-013	7.0	3.8	2.0	4.0	1.5
IW-014	7.7	6.0	3.4	6.0	2.0
IW-015	6.0	4.5	2.0	5.0	1.5
IW-016	12.0	10.0	7.0	8.3	2.0
IW-017	12.0	9.0	5.5	8.5	1.5
IW-018	5.5	4.0	1.8	4.3	1.3
IW-019	5.9	4.3	2.0	5.0	1.5
IW-020	6.2	3.7	1.7	5.0	1.0
IW-021	13.0	9.0	4.3	7.0	2.0
IW-022	10.0	6.8	4.2	10.0	2.0
IW-023	14.0	10.0	6.5	9.8	3.0
IW-024	15.3	11.8	7.5	10.0	3.0
IW-025	12.0	10.0	7.1	6.0	2.0
IW-026	6.5	4.9	3.3	6.5	1.5
IW-027	7.8	6.0	3.4	4.8	1.8
IW-028	4.2	3.0	2.0	5.0	1.0
IW-029	4.2	3.0	1.0	4.0	1.0
IW-030	5.9	4.0	2.0	8.0	1.2
IW-031	7.8	6.0	3.5	8.0	1.6
IW-032	17.7	12.8	7.0	18.7	3.0
IW-033	14.0	10.4	6.6	18.0	2.5
IW-034	11.7	9.5	5.5	8.2	2.4
IW-035	12.0	9.6	6.2	10.5	2.1
IW-090	8.0	5.4	2.5	5.5	1.5

Our ceramic eyelet guides are made from fine Alumina (Al_2O_3), which provides excellent resistance to wear from heat and friction.

The ceramic surfaces are polished to a mirror finish in order to reduce friction to a minimum.

These eyelets are normally used for guiding the wire during coil winding operations, but also have many applications in the wire manufacturing and textile industries.

Standard stock sizes are highlighted in green; all other sizes are available subject to minimum order quantities.

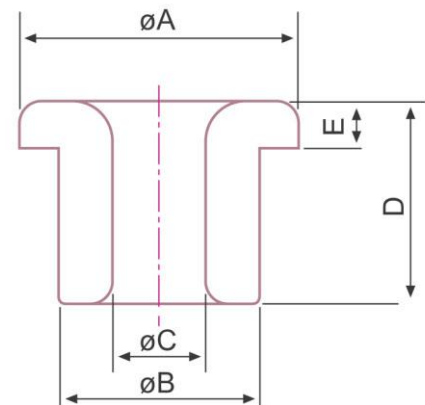

We aim to be much more than a machinery supplier. Our team has a vast range of winding experience and is able to offer help and advice on all aspects of coil winding, from tooling design to machine choice and set-up.

~ Coil winding solutions you can rely on ~



Working with local partners in the following countries;

Austria, Czech Republic, Germany, Hungary, Poland, Portugal, Romania, Slovakia, Slovenia, Spain, Sweden.